

SQUARE IN CIRCLE
S T U D I O

HALF IN CIRCLE – TABLE LAMP

REF TL 018

Inspired by costume design from the Triadic Ballet by Oscar Schlemmer, geometric forms are combined to form a very sculptural light. The cylindrical base is attached to a circular ring whilst light emanates from a semi-circle element hanging down. Crafted from two tone metal and opaque glass, shown in brushed brass with grey metal.

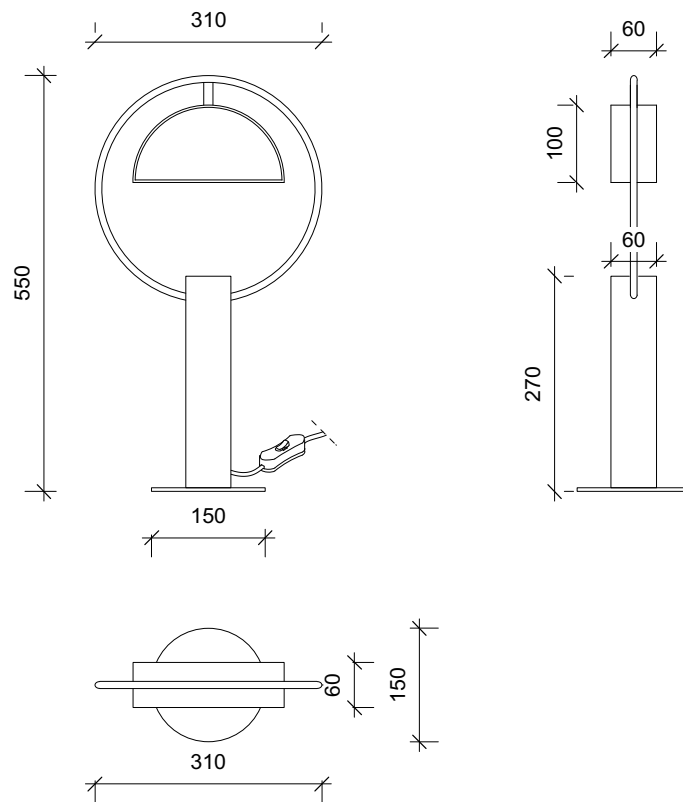

MATERIAL:

Electroplated Iron/ hand brushed finish

LIGHT SOURCE: Integrated LED light strip

FINISH:

Brushed brass/ brushed grey metal/ white frosted glass
(Other finishes available)

WATTAGE: 7W

COLOUR : 3000K

DIMENSION :

Height	550mm	21.6"
Ring Dia	310mm	12.2"
Light Source Width	60mm	2.3"
Base Dia	150mm	6"

NET WEIGHT: 2.6kg 5.7lb

INFO@CKSCollective.COM



WWW.CKSCollective.COM