

SQUARE IN CIRCLE  
S T U D I O

## STRIP – WALL LIGHT

REF WL 054

This simple yet striking wall light is inspired by the 1920s “Slat” ballet by Bauhaus artist Oskar Schlemmer. The distinctive feature of this piece was a specific costume that connects poles to the body of the dancer in order to limit his movements and also underline the direction of the movements in space. Our “Split” wall light is based on the same principle. The glass tubes are connected to the marble and brass lamp body and give an ambient glow.

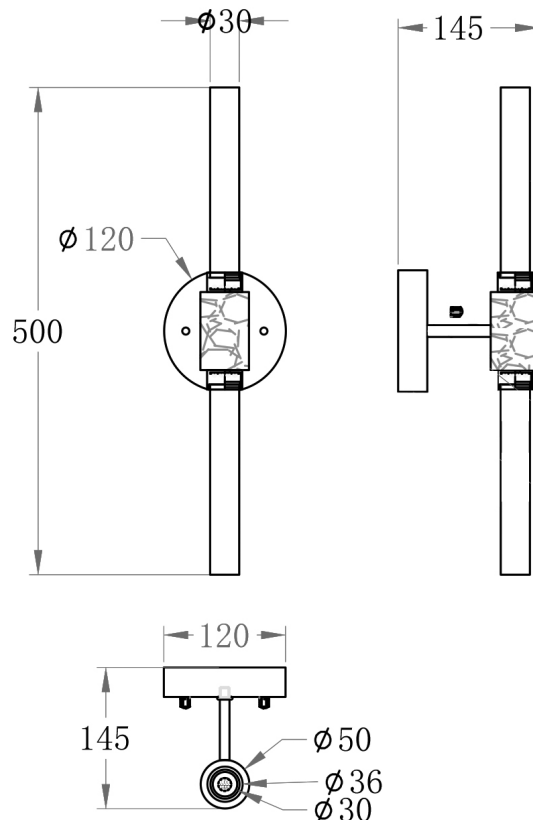

### MATERIAL:

Electroplated Iron/ hand brushed finish

LIGHT SOURCE:

G9 LED

WATTAGE:

5W

### FINISH:

Brushed brass/black marble/ white acrylic diffuser  
(Other finishes available)

VOLTAGE:

220V,

COLOUR :

3000K (warm white)

### DIMENSION :

Height 500mm  
Width 120mm  
Projection 145mm

NET WEIGHT:

2.3kg

5.5lb

INFO@CKSCollective.COM

CKS  
COLLECTIVE

WWW.CKSCollective.COM