



GABRIEL SCOTT

EST. 2012



**WELLES**  
**Double Blown**  
**Glass Pendant**

in Satin Brass  
& Smoked Gray

An intricate design process in which colored glass is blown within a clear glass envelope, the Welles double blown glass diffuses a soft light filtered through its translucent facets. A polygonal shape with polished sharp edges, the Welles is a glistening gem that cascades as a single pendant or as a body of staggering pendants.

The precious Welles Double Blown Glass is available in smoked gray or alabaster white, and can be mixed or matched with its complementary black, nickel, brass, copper and bronze metal.

All Gabriel Scott pieces are handmade in Canada.

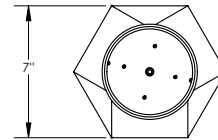
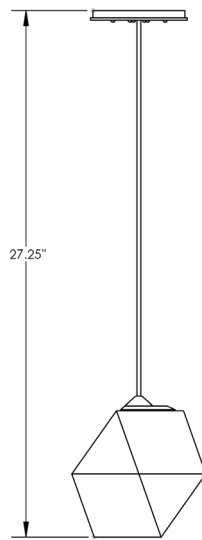
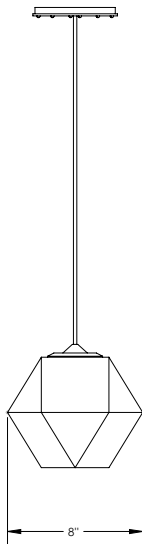

## SPECIFICATIONS

### Standard Finishes:

Blown Glass: Alabaster White or Smoked Gray

Metal: Blackened Steel, Satin Nickel,  
Satin Brass or Satin Copper

### Specifications:

Dimensions: 8" x 7" x 7.25" H + Drop

20 cm x 18 cm D x 19 cm H + Drop

Weight: 5 lbs / 2.27 kg

Light Source: 12V 6 Watt LED (included)

LED Drivers: CCT9W500 - 110V  
UVC1225TD - 220V

Standard Lead time: 8 - 10 weeks

### Cables & Canopies:

Standard Drop: 20" / 51 cm, adjustable upon installation

(increased cable-lengths available upon request)

Standard Canopy: 5" x 0.5" / 12 cm x 1.3 cm

Deep Canopy: Available upon request.

Custom finishes available upon inquiry.

Made and assembled in Canada. Item is UL & CE listed.



## STANDARD FINISHES

### Double Blown Glass:



Alabaster White

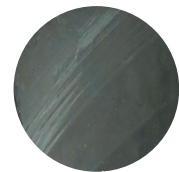

Smoked Gray

### Metal:

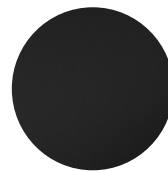

Blackened Steel

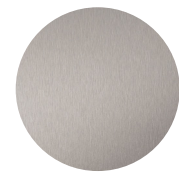

Satin Nickel



Satin Brass



Satin Copper



Satin Bronze

# LED DRIVER

CCT9W500 - 110V

Magnitude's CCT Series dimmable Constant Current LED driver is class 2 rated and designed to operate with MLV, ELV and CL dimmer switches (forward phase/ reverse phase / TRIAC). The driver's low profile case allows OEM's to easily incorporate it into Luminaires. A 5-year warranty is a standard on all of Magnitude's products.

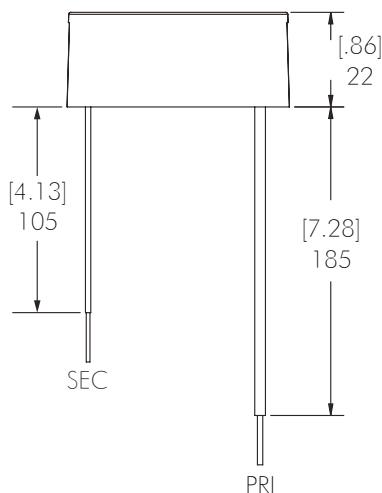
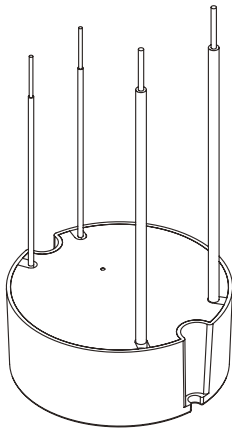
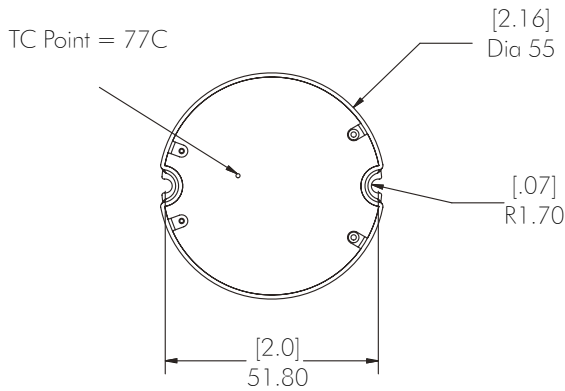

## Features:

- Dimmable with MLV, ELV and CL dimmer switches (forward phase / reverse phase / TRIAC)
- Dim down to 5%
- Super compact case
- Class 2
- UL 8750
- Complies with FCC Part 15B
- Auto-Reset protection for short circuits, over-voltage and over-temperature

## Specifications:

Input voltage	100 - 120VAC
Max output voltage	9W
Output voltage range	12 - 18.5 VDC
Output current range	500mA Nominal - 525 Max
Rated output power	6 - 9.25W
Efficiency at max load	> 82 %
THD at max load	< 20 %
Power factor at max load	> 0.9
Environment protection rating	IP21 - Dry and damp location
Tc case max	77c
Ambient op. temp.	-20c ~ 60c
Operating humidity	10% - 60%
Lifetime	50KHrs
Over voltage protection	Auto recovery
Open circuit protection	Max output voltage
Short circuit protection	Auto recovery
Surge protection	1KV
Weight	82g
Dimensions (inches)	2.16" D x 0.86" H
Dimensions (cm)	5.5 cm D x 2.2 cm H
Placement	Designed to fit in standard 4" junction box

# LED DRIVER

## UVC1225TD - 220V

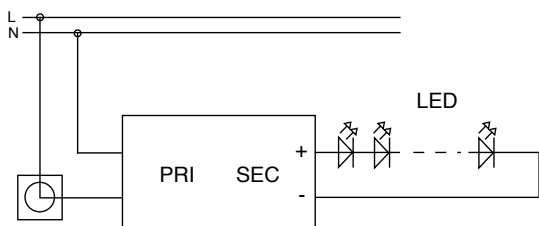
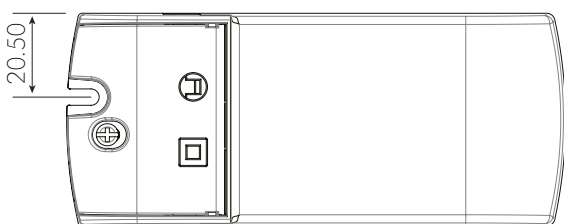
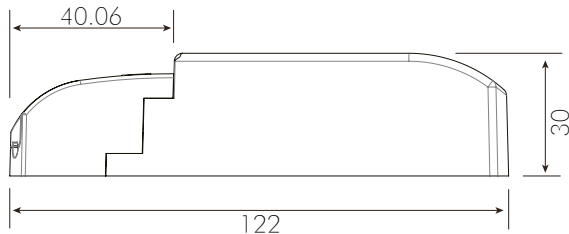

### Features:

- Constant voltage output
- Fully isolated
- Short circuit, over current and over voltage protection up to 80% efficient
- Fire resistant plastic cover
- Compatible with leading and trailing edge dimmers
- 10 ~ 100% Dimming Load
- 10 ~ 100% Dimming range
- Mains dimmable
- Push terminals for easy installation
- IP44 design for indoor use
- 2 years warranty

### Specifications:

Voltage	220V ~ 240VAC
Frequency	50-60 Hz
Current	0.2A
Inrush Current	<2.5A
Power Factor	0.95
Load Voltage	12V
No Load Voltage	12V
Current	2.08Av
Power	25W
Power Factor	> 0.95
Efficiency	80%
Over Load	Auto Recovery
Short Circuit	Auto Recovery
Over Voltage	Auto Recovery
Operating Temperature	-20 ~ +50°C
Storage Temperature	-40 ~ +70°C
Relative Humidity	5 - 95%
Safety Standard	Design refers to EN60598, EN61547, ENV55024, EN61000-4-2, 3, 4, 6, 8,11, EN61000-3-2, EN61000-3-3
EMI Standard	Meets Emissions to EN55022, EN55015 Class B
Lifetime	50K hrs at TC max (70c)
Weight	110g
Dimensions (inches)	4.8" x 2" x 1.2"
Dimensions (cm)	12.2 cm x 5.2 cm x 3 cm